



Integrated display model

## Intelligent Metering and Control Devices

Used at key distribution points and sensitive loads, the ION® 7550 and ION® 7650 meters offer unmatched functionality including advanced power quality analysis coupled with revenue accuracy, multiple communications options, web compatibility, and control capabilities.

The meters come with an extensive selection of pre-configured data screens and measurements that you can use right out of the box or customize to fit your unique requirements.

For an enterprise energy management solution, the meters can be integrated with our ION EEM software, ION Enterprise® software, or other energy management and SCADA systems via multiple communication channels and protocols.

Patented ION technology lets you customize metering or analysis functions at your workstation, without any hard-wiring. Just graphically link a few drag-and-drop icons, or select default setups, and you're ready to go.

Not all features listed are available with every model. Please refer to the detailed descriptions within for a complete list of feature availability.

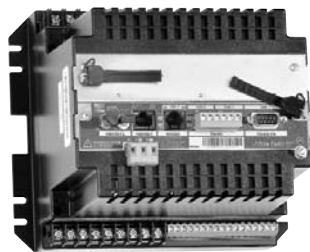

TRAN option

## Applications Summary

### Compliance Monitoring

Use the ION 7650 meter to summarize power quality measurements into simple pass/fail indicators. Monitor compliance with international standards such as EN50160, IEC 61000-4-7 (harmonics), and IEC 61000-4-15 (flicker). Or configure the unit for IEEE 519-1992, IEEE 1159 and SEMI F47.

### Disturbance Analysis

Maintain revenue accuracy at the regular measurement range while simultaneously capturing large-scale disturbances other meters can miss. Discover the sources of power quality events, harmonics, sags and swells. Analyze problems; avoid repeat interruptions.

### Cost Allocation and Billing

Determine cost centers, identify demand control opportunities and check energy consumption patterns.

### Demand and Power Factor Control

Avoid penalties with automated load shedding, scheduling, peak shaving or capacitor bank control.

### Load Studies/Circuit Optimization

Determine the capacity of your electric network and run at peak efficiency. Perform load trending.

### Equipment Monitoring and Control

Improve process yields and extend equipment life. Extensive analog and digital I/O enables system monitoring and control.

### Preventative Maintenance

Set up alarms to warn of pending problems. Log events and alarms for all critical conditions.

### Integrated Utility Metering

Collect, scale, and log water, air, gas, electricity, and steam readings from connected meters or transducers, and deliver the information to head-end systems.

### Instrument Transformer Correction

Use the meter's ITC feature to correct for less accurate transformers, saving money and improving accuracy.

## Features Summary

### Measurements

- ◆ Exceeds Class 0.2 revenue accuracy
- ◆ Instantaneous 3-phase voltage, current, frequency, power factor
- ◆ Energy: bi-directional, absolute, net, time-of-use, loss compensation
- ◆ Demand: rolling block, predicted, thermal
- ◆ Harmonics: individual and total harmonic distortion up to the 63rd (511th in software)
- ◆ Transient detection: 17us at 60Hz, (20us at 50Hz) and sag/swell recording

### Internet-Enabled Communications

- ◆ WebMeter, MeterM@il® allow distribution of metered data and alarms over the Internet
- ◆ Optional built-in modem with ModemGate allows modem access for 31 other devices
- ◆ 10Base-T or 10Base-FL Ethernet port option with EtherGate allows for direct data transfer from Ethernet to RS-485
- ◆ Two RS-485 ports, one switchable to RS-232
- ◆ One ANSI Type 2 front panel optical port
- ◆ Modbus RTU/TCP and DNP 3.0 support
- ◆ Modbus Master support

### On-Board Data Logging

- ◆ Scheduled or event-driven logging
- ◆ Sequence-of-events, min/max, waveform, faults, and transient logging

### Setpoints for Control and Alarms

- ◆ Setpoint on any parameter or condition
- ◆ 1 second or 1/2 cycle operation

### Inputs and Outputs

- ◆ Standard format includes 8 digital inputs, 3 Form C relay outputs (electromechanical) for control functions, and 4 Form A digital outputs (solid state) for pulse functions
- ◆ Also available with 8 additional digital inputs, 4 analog outputs, and/or 4 analog inputs

### Multi-user, Multi-level Security

- ◆ Access to meter information can be controlled and customized for up to 16 designated users with security levels ranging from read access up to administrative rights.



**POWER  
MEASUREMENT**

owned by  
**Schneider  
Electric**

## Energy Display

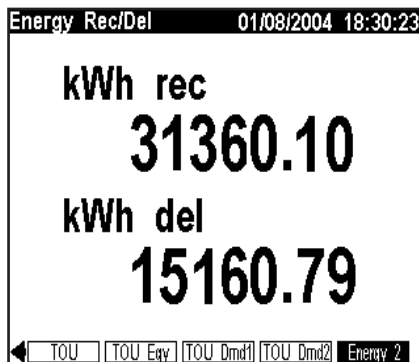

Peak demand with date and time-stamp

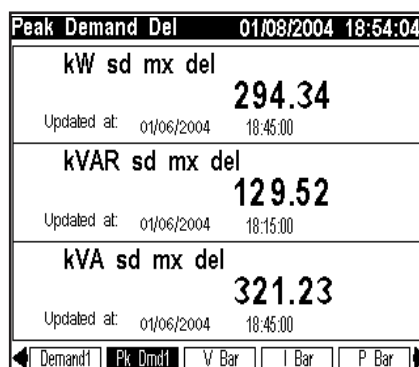

The meter's display system reliability in nines, (e.g. 99.99% up-time).



Display kWh usage trends directly on the meter's front panel

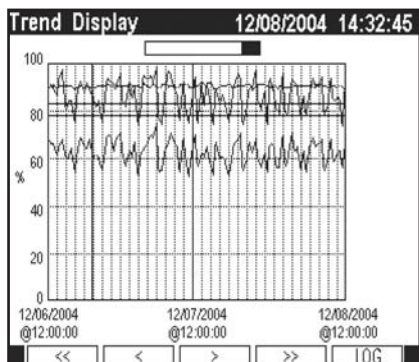

## Front Panel Display

The meters offer unique, easy-to-read 3½ x 4½ inch (87 x 112mm) LCD display screens with bright back lighting and adjustable contrast. They can show TOU, harmonics, event logs, phasors, and instantaneous power parameters. A selection of character sizes enhance visibility under difficult lighting conditions or at long distances. It provides a user-friendly interface with a screen-based menu system to configure meter settings and an extensive choice of pre-configured display screens for common applications.

## Metering Energy

The meters are fully bi-directional and monitor energy in four quadrants. They provide active, reactive and apparent energy parameters and can integrate any instantaneous power parameter to supply measurements like:

- ◆ kWh delivered and received
- ◆ kWh, kVARh, kVAh net (delivered - received)
- ◆ kWh, kVARh, kVAh total (delivered + received)
- ◆ kVARh, kVAh delivered and received
- ◆ Volt-hours and Amp-hours
- ◆ Integration of any instantaneous measurement

Energy registers can be logged automatically on a programmed schedule.

## Demand

The meters support all standard demand calculation methods, including block, rolling block, thermal (exponential), and predicted demand. They can measure demand on any instantaneous value and record peak (maximum) and minimum demand with date and time-stamps to the second. Peak demand registers can be reset manually (password protected) or logged and reset automatically on a programmed schedule. Measurements include:

- ◆ kW, kVAR, kVA demand, min/max
- ◆ Amps, Volts demand, min/max
- ◆ Demand on any instantaneous measurement

## Trending

Both meters offer access to historical data right at the front panel. The meters display, trend and continuously update historical data with date and timestamps for up to four parameters simultaneously.

## Instantaneous

Both meters provide a choice of high accuracy, 1 second or high-speed, ½ cycle measurements, including true RMS, per phase and total for:

- ◆ Voltage and current
- ◆ Active power (kW) and reactive power (kVAR)
- ◆ Apparent power (kVA)
- ◆ Power factor and frequency
- ◆ Voltage and current unbalance
- ◆ Phase reversal

## Time-Of-Use

The meters offer comprehensive time-of-use (TOU) metering. A 20 year calendar is configurable in accordance with virtually any utility tariff structure. TOU register values can be automatically recorded at user-specified time intervals, at pre-scheduled dates and times, or when internal or external events occur.

## Transformer/Line Loss Compensation

- ◆ Flexible compensation methods
- ◆ Easy configuration
- ◆ Updated every second
- ◆ Available through all supported protocols

## Instrument Transformer Correction

The meters provide high-accuracy instrument transformer correction, allowing you to use lower-accuracy, lower-cost transformers while retaining high-accuracy transformer function.

## Power Quality Metering

### Compliance Monitoring\*

- ◆ EN 50160 compliance monitoring
- ◆ IEC 61000-4-7 harmonics and inter-harmonics\*\*
- ◆ IEC 61000-4-15 flicker
- ◆ CBEMA/ITIC
- ◆ IEEE 519 and IEEE 1159

### Waveform Recording

The meters can simultaneously capture all voltage and current channels.

- ◆ Sub-cycle disturbance capture
- ◆ The maximum number of cycles for contiguous waveform capture is 214,000 (based on 16 samples/cycle x 96 cycles and the largest capacity of meter memory)
- ◆ Up to 512 samples/cycle standard, 1024 samples/cycle optional with the ION 7650
- ◆ Up to 256 samples/cycle with the ION 7550
- ◆ Dynamic range: Voltage inputs - 16 bits effective; Current inputs - 19 bits effective

### Measure Up-time Using Nines

The current electricity supply infrastructure can typically provide electricity with 99.9% reliability, (3 nines or 8.8 hours downtime a year). However, any disruption is unacceptable for businesses in the digital economy that can require up to 99.9999999% (9 nines or 2 cycles downtime per year) to effectively run their business model. Measure the number of nines of reliability with the ION 7550 and ION 7650.

### Out-of-Limit Detection

Detect, record, and report the specifics of voltage or current imbalances and loss, frequency/power factor variations, over and undervoltages, etc.

\* Available only on ION 7650

\*\* Compliant with input signals up to 59kHz

**Performance Indicators**

The meters can be configured to monitor a wide range of utility performance indicators, including:

- Total outage time (in seconds)
- Out-of-tolerance duration for total harmonic distortion, voltage, frequency, power factor and hundreds of other definable indices

**Harmonic Distortion Metering**

Complete harmonic distortion metering, recording and real-time reporting, up to the 63<sup>rd</sup> harmonic (511<sup>m</sup> for ION 7650 via ION Enterprise software) for all voltage and current inputs.

- Individual harmonics (including magnitude, phase and inter-harmonics for the ION 7650)
- Total even harmonics and total odd harmonics
- Total harmonics (even + odd)
- K-factor, Crest factor

**Symmetrical Components\***

Zero, negative and positive sequences including phase and magnitude for voltage and current inputs. Identify harmful voltage and current unbalances in equipment before they cause damage.

**Sag/Swell Detection**

The ION 7550 and ION 7650 meters' sag/swell capture capability can help you analyze the severity/potential impact of sags and swells.

- Magnitude and duration data suitable for plotting on voltage tolerance curves
- Per-phase triggers for waveform recording or control operations

**Transient Capture\***

- The ION 7650 meter can detect and record sub-cycle transients as short as 17us at 60Hz (20us at 50Hz)

**Data and Event Recording**

The meters provide 5MB (up to 10MB factory option) of configurable, nonvolatile memory for waveform, event and log storage.

**Load Profiling**

The ION 7550 and ION 7650 meters incorporate 800 channels via 50 data recorders. Channel assignments are configurable for historical trend recording of energy, demand, voltage, current, power quality, or any other measured parameter. Trigger recorders based on time interval, calendar schedule, alarm/event condition, or manually.

**High-Speed Data Recording**

High-speed "burst" recording (as fast as 1/2-cycle intervals) stores detailed characteristics of disturbances or outages. Trigger recording by a user-defined setpoint, or from external equipment. Gated recording logs data only during the critical event so that memory is conserved.

**Coincident Min/Max Recording**

Log the values of key parameters or equipment conditions coincident with an extreme condition, complete with date/time stamping. For example, record all feeder voltages and currents at the moment a peak demand condition occurs.

**Time Synchronization and GPS**

A real-time clock allows internal events and data records to be date-stamped and time-stamped to millisecond resolution. The clock can be synchronized to any one of three sources:

- The meter's internal crystal (+/- 5ppm @ 0° to 40°C, 32° to 104°F)
- The line frequency of the electrical network being metered, which is accurate to 3 seconds per month (+/- 1 ppm)
- An external GPS receiver with an accuracy of +/- 1 millisecond

The serial port used for GPS time synchronization is dedicated exclusively as a GPS input.

**Logic, Math and Control**

Perform on-board calculations on any measured value, calculate true quantities from pulse inputs (e.g. BTUs) and calculate transformer loss compensation values. You can also implement real-time billing schemes.

**Mathematical Functions**

Define formulas using the following operators:

- Arithmetic (+, x, -, ÷)
- Comparison (>, <, =, ≥, ≤, ≠)
- Logical (AND, OR, NOT, TRUE, FALSE, IF)
- Trigonometric (SIN, COS, TAN, ASIN, ACOS, ATAN)
- Math (PI, SQRT, POWER, SUM, SUMSQ, AVG, RMS, LOG10, LN, MAX, MIN)

**Programmable Logic and Setpoints**

24 setpoints can be set for 1-second or 1/2-cycle operation and can be triggered by any over or under condition. Setpoints can trigger:

- Audible (through software) and visible alarms
- Modem/pager dial-back
- Data logging
- Waveform recording with control over pre-event and post-event capture
- Relay control
- Clearing and reset functions
- Relative setpoints

Multiple display formats are available, including bar graphs with min/max indicators

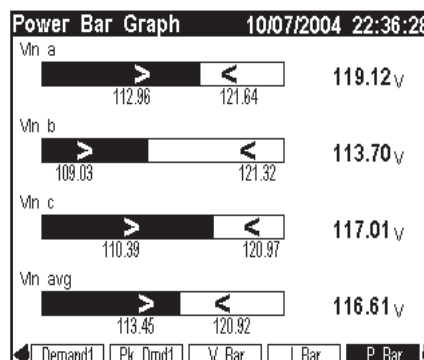

Vector diagram with magnitude and phase angle can help reduce installation time

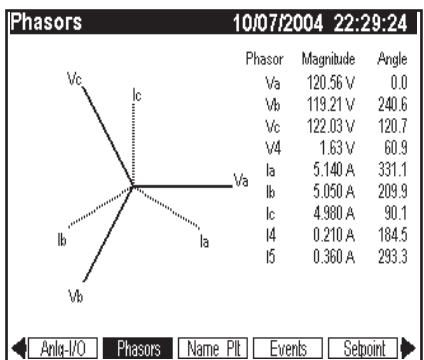

View THD and individual harmonics through the front panel display screen

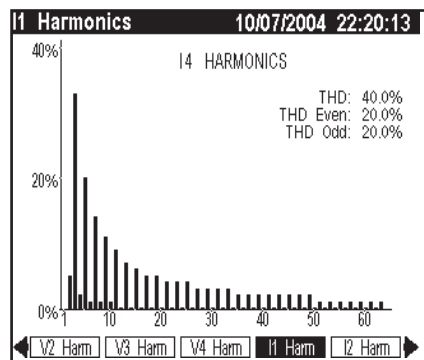

Built-in Web server provides browser access to extensive real-time meter data

Operation	Voltage	Current
Consumption	Vln avg 119.96 V	I avg 4.33
Power Quality	Vln a 119.86 V	I a 3.75
Setup	Vln b 119.97 V	I b 5.00
Network Setup	Vln c 120.04 V	I c 4.25
	Vll avg 207.77 V	I4 0.20
	Vll a-b 207.61 V	I unbal 15.4
	Vll b-c 207.79 V	
	Vll c-a 207.92 V	Power Factor

\* Available only on ION 7650

## Software Integration

Extensive communication capabilities enable the meters to be easily integrated into Power Measurement's software or with other energy management and distribution control systems.

### ION® EEM Software

The meters can be integrated with ION® EEM software, an enterprise level software suite that satisfies a full spectrum of energy management needs, from operational cost reductions to procurement support to cost allocation, benchmarking and budgeting.

### ION Enterprise® Software

The meters are compatible with our Windows-based ION Enterprise operations software, which displays real-time and logged data and offers manual control/configuration capabilities. It provides enterprise-wide data sharing in a secure networked environment.

### ION Setup Software

Both meters are further enhanced by free ION Setup for Windows, a user-friendly setup assistant and software solution that displays real-time data from your power monitoring devices and provides device configuration capabilities.

## Modbus Master

The meters can read and write data to Modbus slave devices through a designated serial port. This powerful feature allows meters to collect data from Modbus devices, process it, then deliver condensed information in a variety of ways.

Modbus Master read ability lets you acquire data from nearby low-cost meters, which can be filed in on-board memory, presented on the graphical display or monitored using built-in setpoints.

Modbus Master write capability lets you perform functions such as controlling remote I/O points, resetting setpoint or configuration parameters on PLCs, and simple data exchange with other information systems.

## Internet Connectivity

### MeterM@il®

Meters equipped with an Ethernet port can automatically email alarm notifications or scheduled system-status updates. MeterM@il messages can be received like any email message, at a workstation, cell phone, pager or PDA. Data logs can also be sent on an event-driven or scheduled basis via email, while conveniently accommodating firewall restrictions.

### WebMeter®

An on-board Web server, combined with an Ethernet port, offers quick and easy access to real-time energy and basic power quality information without special software. Built-in web pages display a range of energy and basic power quality information through any web-enabled device and even support basic meter configuration tasks.

### XML Compatibility

The meters can also exchange information using industry-standard XML format. Its simple machine-readable format supports easy integration with custom reporting, spreadsheet, database and other applications.

## Communications

### Multi-Port, Multi-Protocol Access

Simultaneous communication on up to 4 ports provides secure data sharing with a variety of energy management systems using a choice of communication standards and protocols.

### RS-232/RS-485 Port

Selectable between RS-232 and RS-485

- ◆ Protocols: ION, DNP 3.0, Modbus RTU, GPS, EtherGate, ModemGate, or Modbus Master
- ◆ Baud rate: 300 bps to 115,200 bps

### RS-485 Port

- ◆ Protocols: ION, DNP 3.0, Modbus RTU, GPS, EtherGate, ModemGate, or Modbus Master
- ◆ Baud rate: 300 bps to 57,600 bps

### Infrared Data Port

The ANSI Type 2 compliant optical port can download real-time data to a portable PC.

- ◆ Protocols: ION, Modbus RTU, DNP 3.0
- ◆ Baud rate: 1200 bps to 19,200 bps

### Internal Modem

Available internal telephone modem features fast connect time and ModemGate, a gateway letting up to 31 additional devices share a meter's internal modem via the remaining serial ports.

- ◆ Protocols: ION, Modbus RTU and DNP 3.0
- ◆ Baud rate: Up to 33.6 kbps

### Ethernet Port

Optional 10Base-T or 10Base-FL port offers direct access through an Ethernet LAN/WAN and features EtherGate, which permits the direct transfer of data between an Ethernet network and up to 62 devices via the meter's two serial ports.

- ◆ Protocols: TCP/IP, ION, Modbus TCP, DNP 3.0, Telnet, NTP, DNS, and SMTP
- ◆ Baud rate: Up to 10 Mbps

### Interoperability

Concurrent communications ability via multiple protocols allows you to use the advanced features of either meter to extend an existing Modbus, DNP or ION software network. Logs and real-time values are also available through Modbus.

### UTS Software Support

The meters are fully compatible with UTS software platforms including MV-90, MVP, MVRS, MVLT and MVCOMM, and offer a direct Ethernet connection to MV-90.

### Flash-Based Firmware

Perform upgrades via communications without removing the meter from the site.

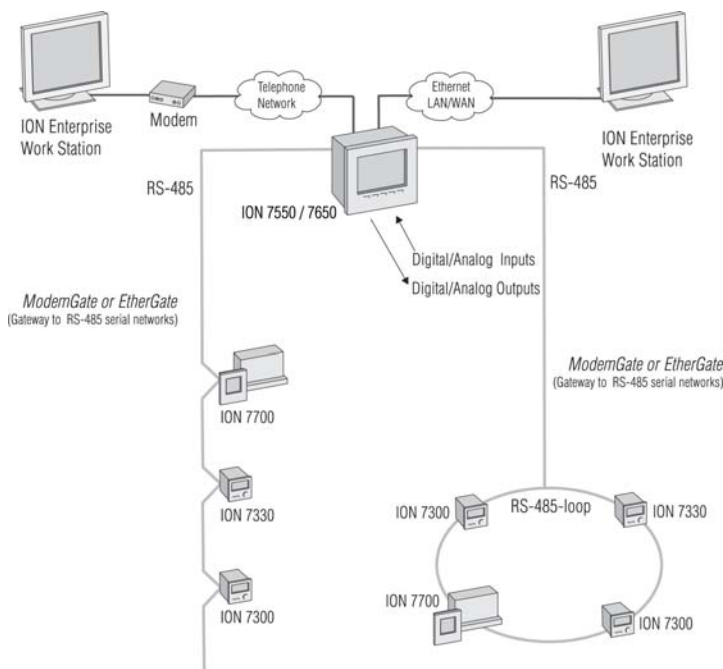

### Inputs/Outputs

Standard digital and optional analog I/O let you monitor a wide range of conditions, such as flow rates, RPM, fluid levels, oil pressures and transformer temperatures. You can output energy pulses to an RTU or perform equipment control operations. The ION 7550 can also be ordered in an optional, dedicated Remote Terminal Unit (RTU) configuration. Please see the ION 7550 RTU Option datasheet for more information.

### Digital Inputs/Outputs

- ◆ 8 digital inputs can monitor status or count pulses from external “volts free” dry contact
- ◆ 4 solid state output ports and 3 on-board relays can be controlled automatically by internal setpoints or manually via a communications port

### Analog Inputs/Outputs

Either meter can be equipped with an optional analog I/O card featuring:

- ◆ 8 digital inputs
- ◆ 4 analog inputs accepting 0 to 1mA or 0 to 20mA (scalable from 4 to 20mA)
- ◆ 4 analog outputs accepting -1 to 1mA or 0 to 20mA (scalable from 4 to 20mA)
- ◆ 4 analog inputs accepting 0 to 20mA and 4 analog output accepting 0 to 20mA
- ◆ 4 analog inputs accepting 0 to 1mA and 4 analog outputs accepting -1 to 1mA

Contact Power Measurement for I/O combinations supported.

### The Power of ION

The meters are based on our patented object-oriented ION® technology, which ensures the longevity of your metering solution because it can adapt as your needs change and lets you take advantage of our ongoing advances in technology.

The measurements and other functions of both meters are provided by ION modules. You can quickly add or rearrange functions with drag-and-drop icons and a few clicks of a mouse. Imagine new features and build them with ION.

### Mounting

The meters can be panel-mounted in a single DIN standard 186mm x 186mm cutout.

- ◆ Bezel size: 192mm x 192mm (DIN)
- ◆ A distance of 160mm (6½ inches) clearance is required behind the panel (plus allowance for connectors and cables)
- ◆ An adapter plate is available to facilitate the conversion from our 3000 series meters to the ION 7550 and ION 7650 meters. Please contact us for more information.

TRAN models have no integrated display and can be flush-mounted against any flat surface.

### Dimensions

Front view

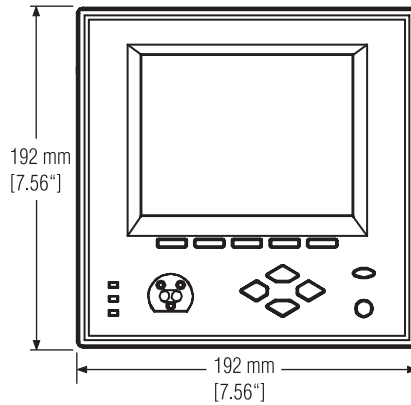

Front view, TRAN model

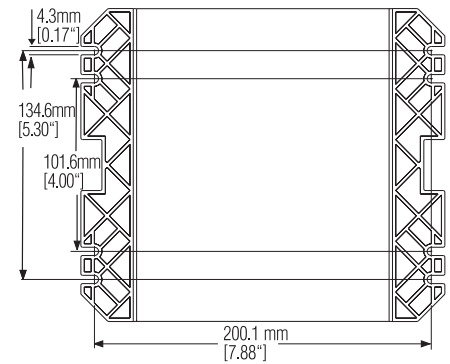

Side view

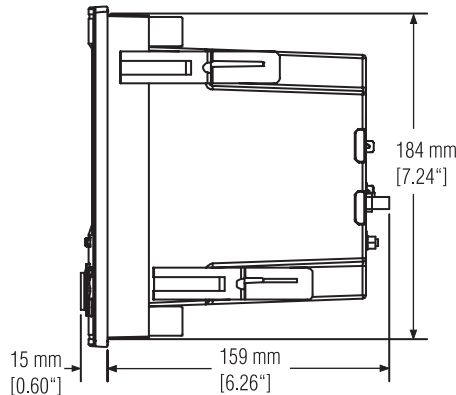

Side view, TRAN model

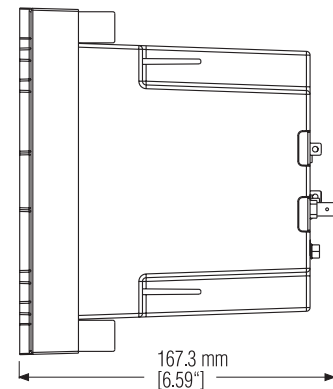

Rear view

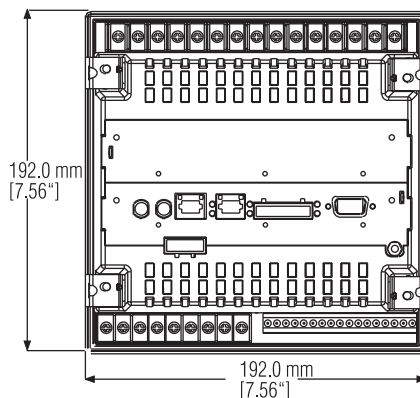

Rear view, TRAN model

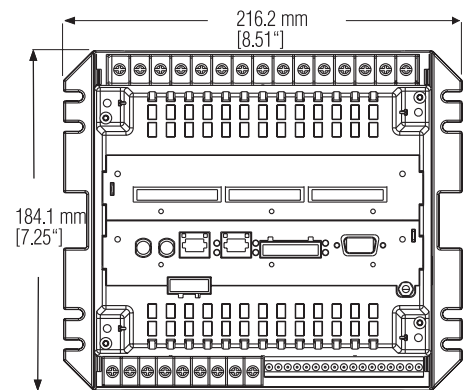

## Example Connections

### 4-Wire Wye (Direct Connection)

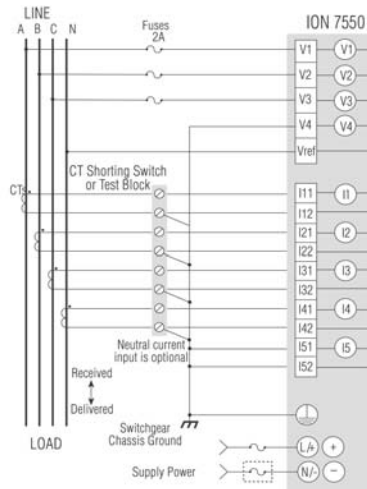

NOTE: Fuse is required if power is supplied from an ungrounded

### 3-Wire Delta (2 PTs and 2 CTs)

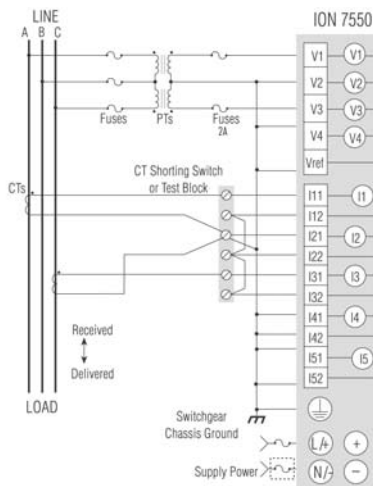

NOTE: Fuse is required if power is supplied from an ungrounded

## Connections

### Installation

- 4-Wire Wye, 3-Wire Wye, 3-Wire Delta, Direct Delta and single phase systems
- 4 voltage and 5 current inputs
- All inputs pass ANSI/IEEE C37.90-1989 surge withstand and fast transient tests

### Voltage and Current Inputs

- Autoranging 57V through 347V LN/600V LL inputs
- No PTs needed for Wye systems up to 347/600VAC
- Standard 5 to 20A current inputs
- Optional 1A current inputs
- Low voltage current probe option

### Control Power

The meters' standard power supply has a voltage range of 85 to 240VAC and 110 to 330VDC, and can be powered from a dedicated fused feed. An optional low voltage DC power supply with a 20 to 60VDC range is also available.

## Measurement Specifications†

Parameter	Accuracy ± (%reading)
	1 second
Voltage (L-L) (L-N)	0.1%
Frequency	±0.005Hz
Current (I1, I2, I3)	0.1%
Current (I4, I5)	0.4%
KW, kVAR, kVA	class 0.2*
kWh, kVARh, kVAh	class 0.2*
KW, KVA Demands	class 0.2*
Power Factor (at Unity PF)	0.2%
Harmonics (to 40th)#	IEC 61000-4-7
Harmonics (to 63rd)	1% Full Scale
K Factor	5% Full Scale
Crest Factor	1% Full Scale
Symmetrical Components#	Voltage: 0.2% FS**, Current: 0.4% FS**

† Refer to User's Manual for valid measurement ranges \* Refer to Compliance section on page 7

Not applicable for NICT meters, contact factory for #ION 7650 only

measurement specifications \*\* FS = Full Scale

Display resolution meets or exceeds accuracy.

## User Programmable Log Capacity - Example Configurations:

	ION 7550		ION 7650	
	500 Events	500 Events	500 Events	500 Events
Data <sup>A</sup>	1.5 years	3.1 years	1.3 years	2.9 years
Waveforms	180 <sup>B</sup>	180 <sup>B</sup>	360 <sup>C</sup>	360 <sup>C</sup>

<sup>A</sup> 16 parameters recorded every 15 minutes

<sup>B</sup> 30 waveforms on 6 channels at the maximum sampling rate

<sup>C</sup> 30 waveforms on 12 channels with any selectable format (for example, 6 channels are 512 samples per cycle)

## Specifications

### Voltage Inputs

- Inputs: V1, V2, V3, V4, VREF
- Rated input: 347 LN/600 LL VAC RMS
- Overload: 1500VAC RMS continuous
- Dielectric withstand: 2500VAC RMS, 60Hz for 1 minute
- Impedance: 5M Ω/phase (phase-Vref)
- Fault capture: 1200 Vpeak

### Current Inputs

- Inputs: I1, I2, I3, I4, I5

### Standard Current Transformers:

#### Standard Current Range:

- Rated nominal: 5A, 10A, and/or 20A (ANSI current class 2 & 10)
- Starting current: 0.005A RMS
- Fault capture: 70A (instantaneous) peak
- Max. voltage: 600V RMS (CAT III IEC61010-1)
- Overload: 500A RMS for 1 second, non-recurring
- Dielectric withstand: 2500VAC, 60Hz for 1 minute
- Burden: 0.05VA per phase (at 5A)
- Impedance: 0.002 Ω/phase (phase-Vref)

#### Optional Current Range:

- Rated nominal: 1A, 2A, 5A, and/or 10A (ANSI current class 10 & 20)
- Starting current: 0.001A RMS
- Fault capture: 17.5A (instantaneous) peak
- Max. voltage: 600V RMS (CAT III IEC61010-1)
- Overload: 50A RMS for 1 second, non-recurring
- Dielectric withstand: 2500VAC, 60Hz for 1 minute
- Burden: 0.015VA per phase (at 1A)
- Impedance: 0.015 Ω

### Current Probes with AC Voltage Output

- Rated inputs: 1V RMS
- Overload: 5.5V (CAT I IEC 61010-1)
- Impedance: 220k Ω max.
- 2 options:
  - Current Probe Inputs for use with 0-1 VAC current probes. Probes sold separately. Accuracy depends on probe specs
  - Current Probe Inputs with 3 calibrated Universal Technic 10A clamp-on CTs, meeting IEC 61036 accuracy

### Digital Inputs

- 8 Inputs: S1-S8, SCOM Self-excited, dry contact sensing, no external voltage required
- Minimum pulse width: 1ms
- Maximum pulse rate: 20 pulses/sec.
- Timing resolution: 1ms
- Update rate<sup>±</sup>: 1/2 cycle (after timing resolution)
- Isolation: 300Vpeak for 10s, 60Hz
- Max rated voltage 120VDC (external excitation)

## Electromechanical Relays

- 3 Form C relays: R1 - R3
- Form C contacts: NO, K, NC  
NO, K and NC are abbreviations for "Normally Open," "Common," and "Normally Closed" - they correspond to terminals R11, R12, and R13 respectively on relay #1.
- Rated voltage: 250VAC / 30VDC
- Rated load at rated voltage:
  - Resistive: 10A AC/DC
  - Inductive: 7.5A (AC, PF = 0.4) / 5A (DC, L/R = 7ms)
- Max. voltage: 380VAC / 125VDC
- MOV protection: 300V max between NO and NC
- Max. load at max. voltage: 0.2A (DC) / 3A (AC)
- Turn-on time: 15ms max.
- Turn-off time: 5ms max.
- Isolation: 5,000VAC for 1 minute
- Lifetime:
  - 10,000,000 operations (no load)
  - 100,000 operations (rated voltage and load)
- Update rate $\ddagger$ : 1/2 cycle or 1 second

## Solid State Outputs

- 4 Form A outputs: D1-D4
- Maximum voltage: 30VDC
- Maximum current: 80mA
- Isolation: Optically isolated. Max. 5000V RMS isolation (UL:E64380)
- Update rate $\ddagger$ : 1/2 cycle or 1 second

## Analog Outputs (optional)

- Outputs: 4: A01 - A04
- Signal type: DC current
- Range: 0-20mA (scalable 4-20) or -1-1mA (scalable 0-1)
- Driving capability: 500 Ohms (20mA) or 10k Ohms (1mA)
- Accuracy: +/-0.2% of full scale
- Update rate $\ddagger$ : 1/2 cycle or 1 second
- Isolation: 750V to earth

## Analog Inputs (optional)

- Inputs: 4: AI 1 to AI 4
- Signal type: DC Current
- Range: 0 to 20mA (scalable 4 to 20), or 0 to 1mA
- Input impedance: 24 Ohms (20mA), or 475 Ohms (1mA)
- Accuracy: +/-0.2% of full scale
- Update rate: 1 second
- Isolation: 750V to earth
- Common mode: Max. 400k Ohms (channel to channel)

## Power Supply

- Standard: AC: 85 to 240VAC (+/-10%), 47 to 63Hz; DC: 110 to 300VDC (+/-10%)  
Burden: Typical 15VA, Max 35VA
- Optional: Low Voltage DC Power Supply  
Rated inputs: DC: 20 to 60VDC (+/- 10%)  
Burden: Typical 12VA, Max 18VA
- Dielectric withstand: 2000VAC RMS, 60Hz for 1 min.
- Ride-through: Min: 100ms (6 cycles at 60Hz at 96VAC), 200ms (12 cycles at 60Hz at 120VAC), 800ms (48 cycles at 60Hz at 240VAC)

## Communications

### Serial Ports

- 1 RS-232/485 and 1 additional RS-485 port
- Protocols: ION, DNP 3.0, Modbus RTU, GPS, EtherGate, ModemGate, Modbus Master
- Baud rate: RS-232 - 300bps to 115,200bps
- Baud rate: RS-485 - 300bps to 57,600bps

### ANSI Type 2 Optical Port

- Interface: ANSI Type 2 Optical Port
- Baud rates: 1200-19,200bps
- Duplex: Half
- Protocols: ION 2.0, Modbus RTU, DNP 3.0
- Location: Front of Meter

### Internal Modem

- Data rate: 300bps - 33.6kbps (V.3.4, V.32 bis, V.32, V.22 bis, V.22 A/B, V.23, V.21, Bell 212A, Bell 103)
- Automatic data rate detection is supported
- Error correction: V.42 LAPM, MNP 2-4, MNP 10
- Data compression: V.42 bis/MNP 5
- Interface: RJ11 (tip and ring)
- Governmental approvals: FCC P68 (USA), Industry Canada CS-03, CTR21 (Austria, Belgium, Denmark, Finland, France, Germany, Greece, Iceland, Ireland, Italy, Luxembourg, Netherlands, Norway, Portugal, Spain, Sweden, Switzerland, UK)

### Ethernet Port

- Protocols: TCP/IP, Telnet, ION, Modbus TCP, DNP 3.0
- Interface: IEEE 802.3-1993, ISO/IEC 8802-3:1993 (Ethernet) 10Base-T or 10Base-FL (optional)
- 10Base-T:
  - Cabling: Unshielded twisted pair cable, 0.5mm (24 AWG), max. length 110yds (100m)
  - Connector: RJ45
  - Isolation: Transformer isolated, min. isolation voltage: 1500VAC RMS/2250VDC
- 10Base-FL:
  - Cabling: Fiber optic cable, 62.5/125um nominal, wavelength 850nm, max. length 2190yds (2000m)
  - Connector: ST (male)
  - Isolation: Optical

## Environmental Conditions

- Operating temp: -20°C to +70°C (no formation of ice) (-4°F to 158°F)
- Low Voltage DC Power Supply: -20°C to 50°C (-4°F 122°F)
- Storage: -40°C to +85°C (-40°F to 185°F)
- Humidity: 5% to 95% non-condensing

## Shipping

- 7.1 lbs / 3.2 kg
- 17 x 10 x 11 inches (0.98 cu. ft.)
- 40.8 x 24 x 27.9 cm (0.0235 cu. m)

## Display

- Type: FSTN Liquid Crystal Display (LCD)
- Resolution: 320 x 240 pixels (1/4 VGA)
- Temperature: Operating range -20°C to +70°C (-4°F to 158°F)
- Backlight: LED

## Standards Compliance

### Accuracy

- Independent Compliance with IEC62053-22 0.2S, 1A and 5A tested by KEMA\*
- Complies with ANSI C12.20, Class 10 & Class 20
- Complies with Measurement Canada AE-1021\*

Products meet or exceed the accuracy requirements of the standards listed. All products tested internally by Power Measurement. Some products tested by third-party laboratory. Due to form factor of some meters, not all ANSI/IEC compliance tests may apply. Contact Power Measurement for further clarification.

### Safety/Construction

- IEC1010-1 (EN61010-1) Safety requirements for electrical equipment for measurement, control and laboratory use
- CSA C22.2 No 1010-1 Safety requirements for electrical equipment for measurement, control and laboratory use Canadian Standards Association
- UL 61010B-1 Measuring, Testing and Signal Generation Equipment

### Electromagnetic Immunity

- IEEE C.37-90.1-1989 IEEE Standard Surge Withstand Capability (SWC) Tests for Protective Relays and Relay Systems (ANSI) (All inputs except for the network communication port)
- IEC1000-4-2 (EN61000-4-2/IEC801-2) Electrostatic Discharge
- IEC1000-4-3 (EN61000-4-3/IEC801-3) Radiated EM Field Immunity
- IEC1000-4-4 (EN61000-4-4/IEC801-4) Electric Fast Transient
- IEC1000-4-5 (EN61000-4-5/IEC801-5) Surge Immunity
- IEC1000-4-6 (EN61000-4-6/IEC801-6) Conducted Immunity
- IEC1000-3-2 (EN61000-3-2) Limits for harmonic currents emissions (equipment input current < 16 amps per phase)
- IEC1000-3-3 (EN61000-3-3) Limitation of voltage fluctuations and flicker in low voltage supply systems for equipment with rated current < 16 amps
- EN50082-2 Electromagnetic Compatibility, immunity standards for industrial environment

### Electromagnetic Emissions

- FCC Part 15 Subpart B, Class A Digital Device, Radiated Emissions
- EN55011 (CISPR 11) Radiated/Conducted Emissions for industrial, scientific and medical (ISM) equipment
- EN55022 (CISPR 22) Radiated/Conducted Emissions for information technology (IT) equipment
- EN61000-6-4 (EN50081-2) Electromagnetic Compatibility, emissions standards for industrial environment

## Some features are optional.

To identify standard and optional features, please see the 'Product Order Forms' at [www.pwrm.com](http://www.pwrm.com).

Features and Options List	ION 7550	ION 7650
<b>Power, Energy, and Demand</b>		
Voltage/current per phase, average, unbalance	■	■
Power: real, reactive, apparent, power factor, frequency	■	■
Energy: bi-directional, total, import, export, net	■	■
Demand: block, rolling block, thermal, predicted	■	■
<b>Power Quality</b>		
Sag/Swell monitoring	■	■
Symmetrical components: zero, positive, negative		■
Transient detection, microseconds†		17
Harmonics: individual, even, odd, total up to	63 <sup>rd</sup>	63 <sup>rd</sup>
Harmonics: magnitude, phase and inter-harmonics		40 <sup>th</sup>
Sampling rate, maximum samples per cycle	256	1024
Flicker, (harmonics to EN50160, IEC 6100-4-7/4-15)		■
Configurable for IEEE 519 - 1992, IEEE159, SEMI	■	■
Uptime in number of nines	■	■
<b>Logging and Recording</b>		
Standard memory capacity	5MB	5MB
Maximum optional memory capacity	10MB	10MB
Min/max logging for any parameter	■	■
Historical logs, maximum # of channels	800	800
Waveform logs, maximum # of cycles	96	96
Timestamp resolution in seconds	0.001	0.001
Historical trend information via front panel display	■	■
GPS time synchronization	■	■
<b>Communications and I/O</b>		
RS-232/485 ports	1	1
RS-485 ports	1	1
Ethernet ports	1	1
ANSI Type 2 Infrared optical port	1	1
Internal modem	1	1
3-port DNP 3.0 through serial, modem, Ethernet and I/R ports	■	■
Modbus RTU slave on serial, modem and I/R ports	■	■
Modbus RTU Master on serial ports	■	■
Modbus TCP through Ethernet	■	■
EtherGate, data transfer between Ethernet & RS-485	■	■
ModemGate, data transfer between internal modem & RS-485	■	■
MeterM@il, logged data and alarms via e-mail	■	■
WebMeter, on board web server	■	■
Analog inputs	4	4
Analog outputs	4	4
Digital status inputs	16	16
Digital status outputs (standard)	4	4
Relay outputs (standard)	3	3
<b>Setpoints, Alarming, and Control</b>		
Setpoints, minimum response time	1/2 cycle	1/2 cycle
Setpoints, number of	65	65
Math, logic, trig, log, linearization formulas	■	■
Single & multi-condition alarms	■	■
Call-out on alarms	■	■
<b>Revenue Metering &amp; Standards</b>		
ANSI C12.16 accuracy compliant	■	■
ANSI C12.20 0.2 compliant, Class 10 & 20	■	■
IEC 62053-22 0.2S compliant, 1 & 5A*	■	■
IEC 62053-22 0.5S compliant 1 & 5A*	■	■
Measurement Canada approved*	■	■
MV-90 supported	■	■
Transformer/line Loss Compensation	■	■
Instrument Transformer Correction	■	■

† For 60 Hz line frequency, 20us for 50 Hz line frequency

\* Certification Pending

## Meet the World Leader

Power Measurement is the leading provider of enterprise energy management systems for energy suppliers and consumers worldwide. Our ION® web-ready software and intelligent electronic devices comprise a complete, real-time information and control network that supports billing for complex energy contracts and helps improve power quality, reduce energy costs and keep operations running enterprise-wide, 24 hours a day. Our reputation for unparalleled value, quality and service is based on over two decades of innovation and experience.

### Worldwide Headquarters

2195 Keating Cross Rd.  
Saanichton, BC, Canada V8M 2A5  
Tel: 1-250-652-7100 Fax: 1-250-652-0411  
email: [sales@pwrm.com](mailto:sales@pwrm.com)

### Europe

Schulstrasse 6  
91320 Ebermannstadt, Germany  
Tel. +49 (0) 9194-724 765  
Fax +49 (0) 9194-724 766  
email: [pme@pwrm.com](mailto:pme@pwrm.com)



**POWER  
MEASUREMENT**

owned by Schneider Electric

For the most up to date information, go to

[www.pwrm.com](http://www.pwrm.com)

**Toll free 1-866-466-7627**

USA and Canada only

Revision Date: January 2006

© 2006 Power Measurement. Printed in Canada  
70100-0173-02

ION, ION Enterprise, ION 7550, ION 7650, MeterM@il, WebMeter, EtherGate, ModemGate are trademarks of Power Measurement. All other trademarks are property of their respective owners. Any reproduction or re-transmission in whole or in part of this work is expressly prohibited without the prior consent of Power Measurement. Information contained herein is subject to change without notice. Any technical assistance provided by this Power Measurement document for system design or configuration shall be deemed to be a proposal and not a recommendation. The responsibility for determining the feasibility of such proposals rests with the original purchaser and should be tested by the original purchaser.

**YOUR LOCAL  
REPRESENTATIVE**



Certificate No. 002188